



Andy D

CITY OF NAPOLEON
BUILDING & ZONING DEPARTMENT
255 W. Riverview Avenue, PO Box 151, Napoleon, OH 43545
Phone: 419-592-4010 - Fax: 419-599-8393

P-15-0417
Sign

APPLICATION FOR SIGN PERMIT

LOCATION OF PROPERTY: 1650 Commerce Dr - Napoleon, OH

OWNER NAME: KOESER CORPORATION PHONE: 419-599-1650

OWNER ADDRESS: 1650 Commerce Dr. Napoleon, OH 43545

CONTRACTOR NAME: FRANZ NURSERY, LLC PHONE: 260-488-3115

IS CONTRACTOR REGISTERED WITH THE CITY OF NAPOLEON? YES NO

SIGN INFORMATION

TYPE: POST WALL GROUND AWNING

DIMENSIONS: (2) 6'x12' + (1) 5'x10' = TOTAL S.F. 194 (COMBINED)

** PLEASE INCLUDE ANY AND ALL SITE PLANS AND PLANS OF ABOVE SIGNS.

FEES:

\$35.00 BASE UP TO 50 S.F. OF SIGN, PLUS \$0.20 PER ADDITIONAL S.F., NOT TO EXCEED \$150.00 (100-3100-46610)

\$5.00 FLAT FEE FOR TEMPORARY SIGNS, TEMPORARY SPECIAL EVENT SIGNS, AND PORTABLE SIGNS OTHER THAN THOSE EXEMPT FROM FEE. (SEE BELOW)

NO FEE REQUIRED FOR TEMPORARY AND EASILY REMOVABLE 1ST AMENDMENT SIGNS, OR SIGNS RELATED TO RELIGIOUS OR CHARITABLE CAUSES OR EVENTS.

ESTIMATED CONSTRUCTION COST \$ _____

[Signature]
APPLICANT SIGNATURE

10/29/15
DATE

Batch 33212 Check 27485 Date 11/16/15



City of Napoleon Building Department

255 W. Riverview
P.O. Box 151
Napoleon, OH 43545
Phone: (419) 592-4010
Fax: (419) 599-8393
Email:

Sign Permit

Permit Number: P-15-0417
Expiration Date: 11/30/2015

KOESTER CORPORATION
1650 Commerce

Napoleon, OH 43545

Description:

\$63.80 Sign

Sign > 50 Sq. Ft.: 194 - \$35.00 + \$0.20000 per

Sign Permit Info

SG_Total sq ft of signs 194

Tom Zimmerman

Authorizing Signature

11/9/15

Date

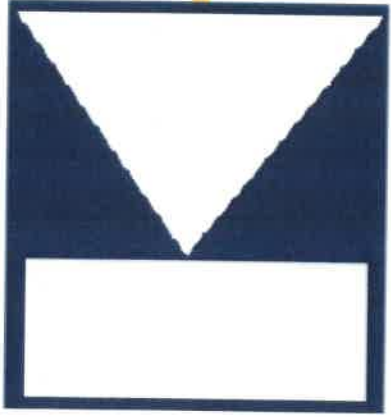

KOESTER
CORPORATION

Industrial Control Experts Since 1970

www.koester-corp.com

MANUFACTURING CENTER

Road Sign Views

Project number	N/A
Date	10/23/15
Drawn by	Author
Checked by	Checker

Koester Corp.
Napoleon, Ohio



S1

Scale 1/2" = 1'-0"

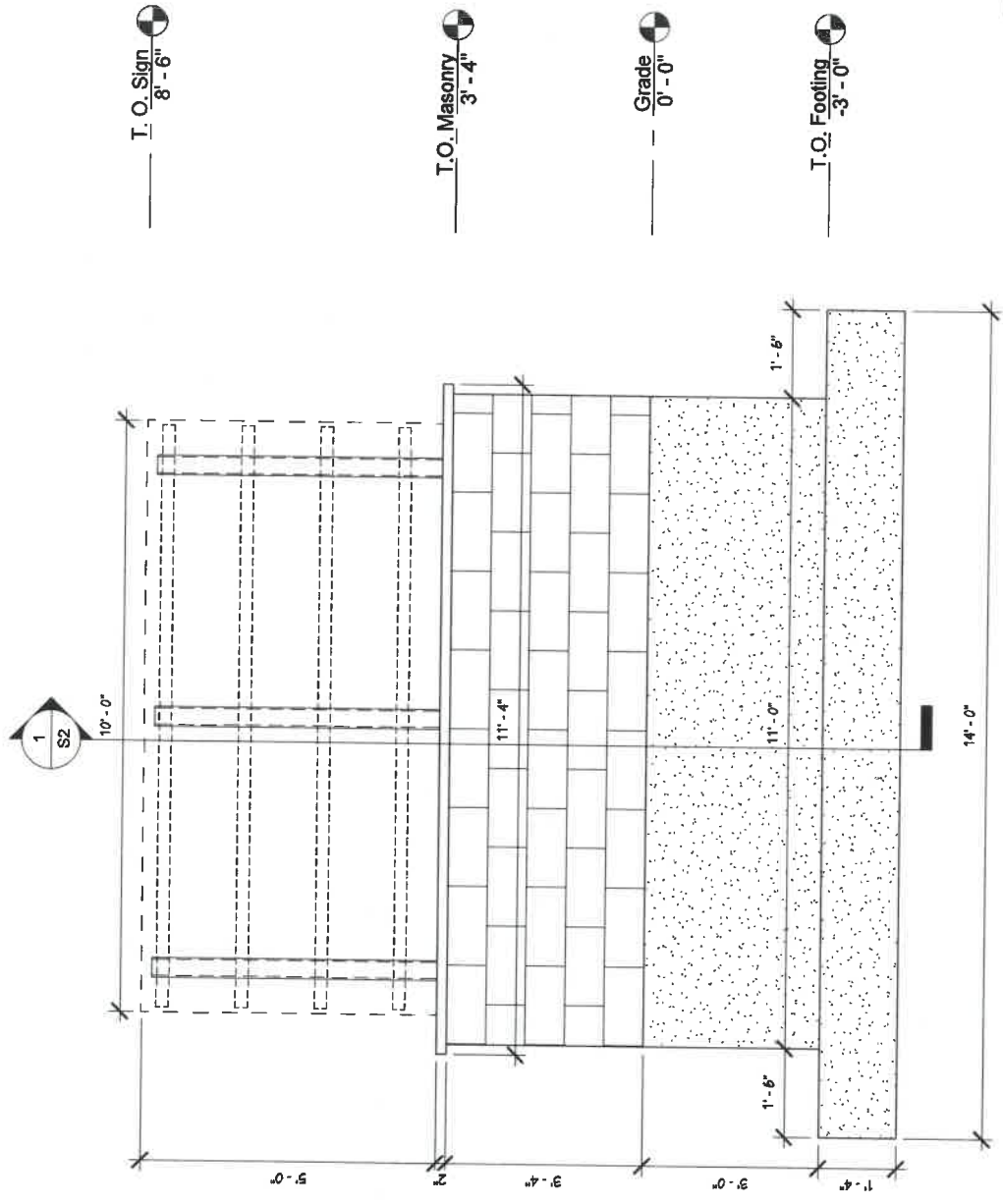

Project number	N/A
Date	10/23/15
Drawn by	AJR
Checked by	AJR

Road Sign Information

S2

Scale As Indicated

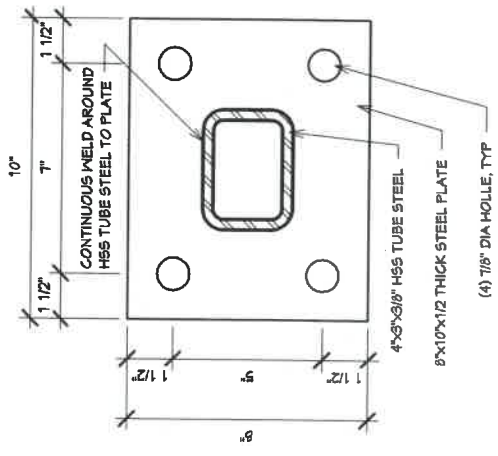
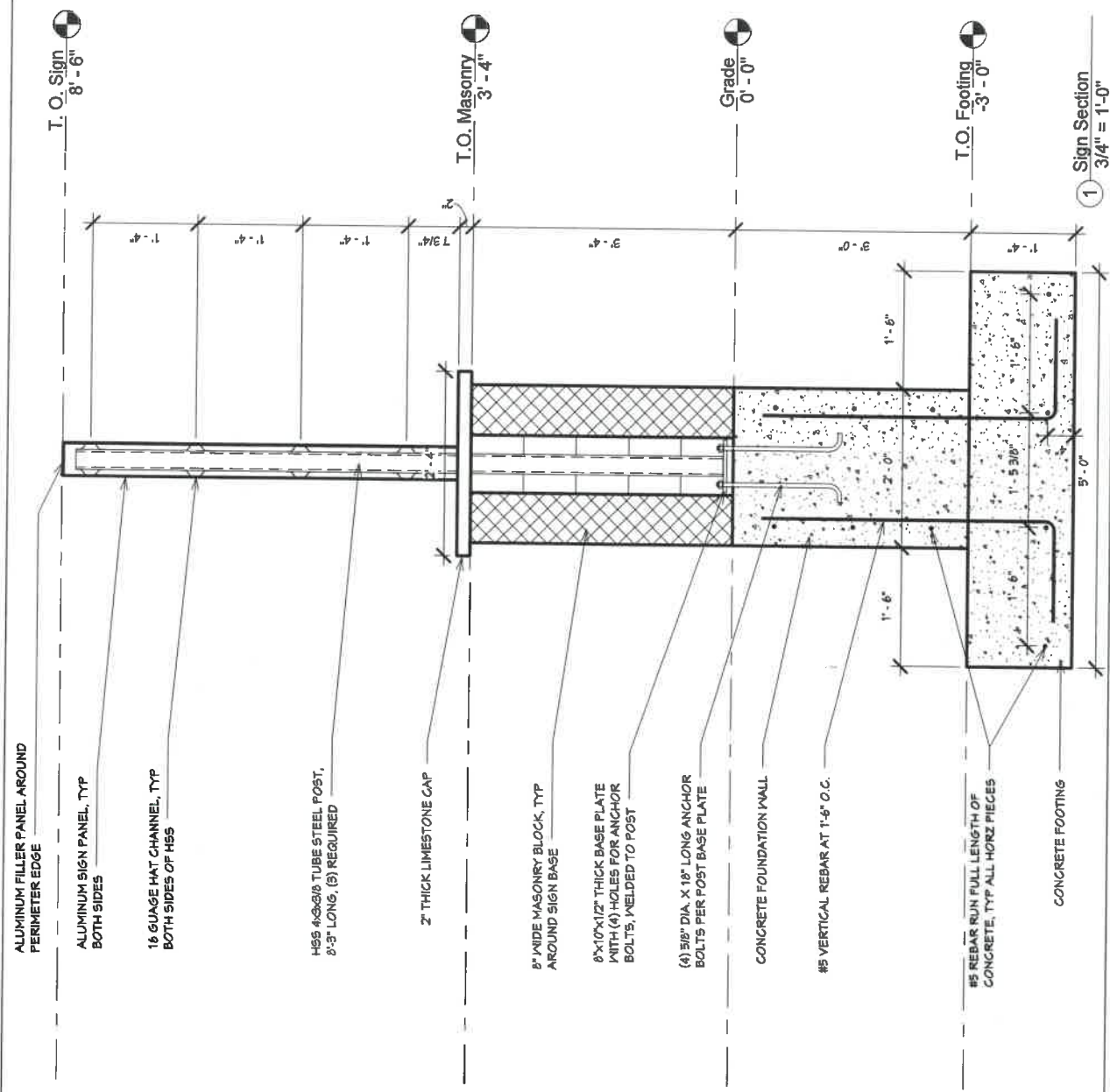



Koester Corp.
Napoleon, Ohio

Project number	N/A
Date	10/23/15
Author	
Checked by	

Stainless Steel "K" Shop Dwg's

S3

Scale 1 1/2" = 1'-0"

SMALL STAINLESS STEEL "K"

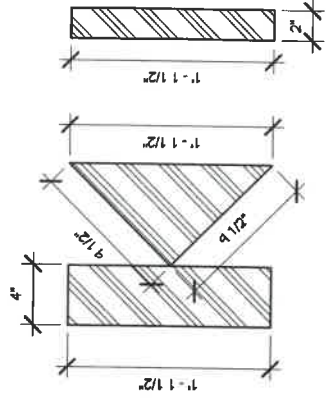

SIDE VIEW

FRONT FACE

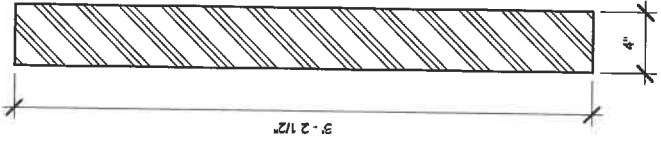

SIDE VIEW

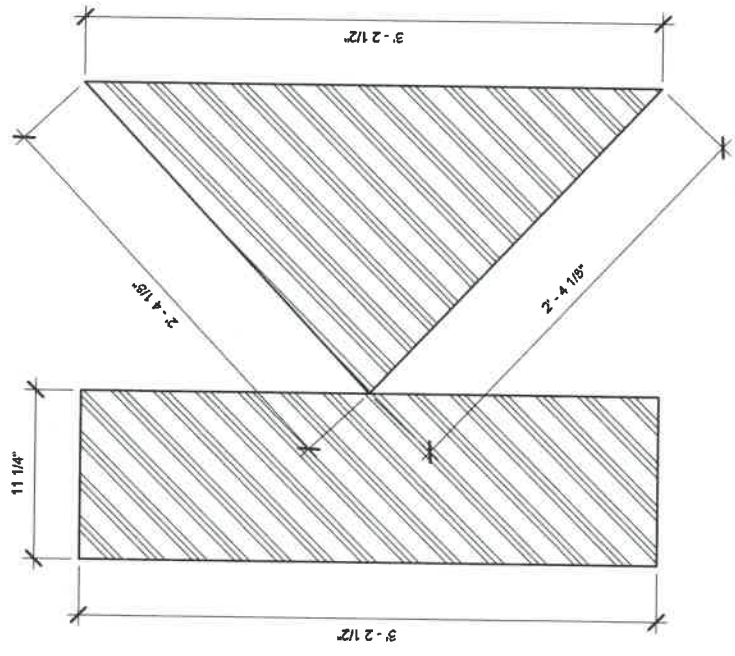

FRONT FACE

LARGE STAINLESS STEEL "K"

1 Stainless Steel K's
1 1/2" = 1'-0"



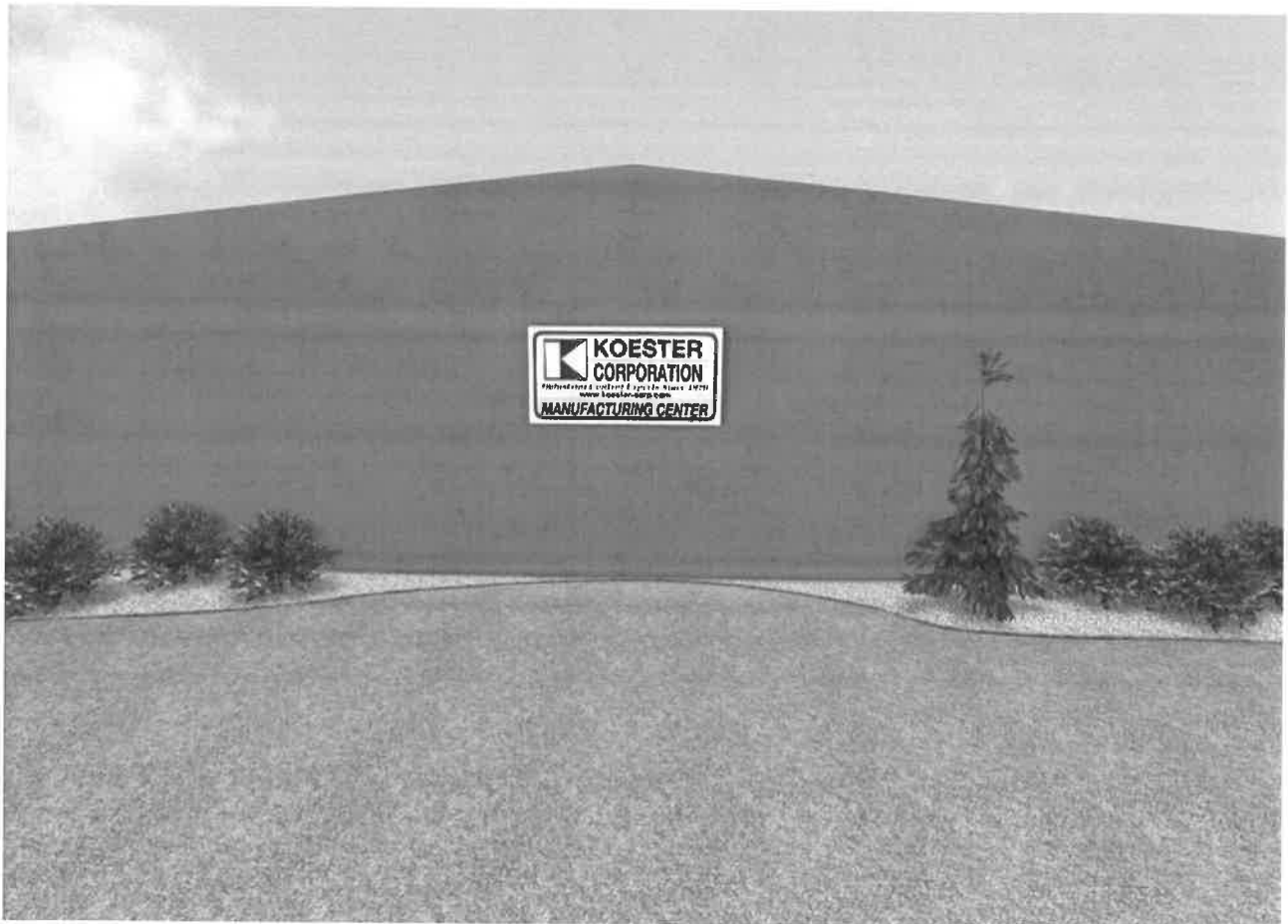

Koester Corporation
1650 Commerce Drive
Napoleon, OH

**Receptacle &
Low-Voltage
Transformer**

**5' x 10' Sign w/ Custom 'K'
(6) Low-Voltage Spot Lights**

**Tennessee Boulder
Accent Walls**

**Tennessee
Bed Divider**

